



RAMÉN KSC

THE COMPLETE AUTOMATED VALVE SOLUTION

High **C**apacity
Compact design
Cost efficient
High **C**ontrolability

RAMÉN KSC IN SHORT

The Ramén KSC series is a brand-new innovative 2 in 1 valve solution that can be used for both control and ON/OFF applications.



Excellent modulating or ON/OFF valve solution.

Automated with pneumatic or electrical actuator.

Sized according to your specific process.

Always in stock.

ABOUT RAMÉN VALVES

We are a Swedish valve manufacturer that have been providing valve solutions for the global process industry since 1945. In everything we do our objective is to deliver environmentally sustainable flow control solutions that prolong your product life cycle and maximize production uptime.

We manufacture the Ramén Ball Sector valve in different configurations as well as the line of Engelsberg industrial valves. Every valve made in our production facilities in Stockholm and Fagersta, Sweden, is carefully manufactured and assembled by professionals according to the most recent ISO quality, environmental and occupational safety requirements.

Besides our skills in production our main focus lies in engineering and sizing the optimal valve solution for each of our customers unique process requirements.



THE 4 C:S OF THE KSC

Capacity. High flow capacity and rangeability. Control from 0-100% opening with 300:1 rangeability. This means 1 valve can be used even for applications having different flow requirements

Control. The valve has an inherent equal percentage characteristic, to manage any process, independently of the deltaP. Due to the trunnion mounting and the zero backlash coupling, the valve also has no hysteresis and offer an excellent repeatability.

Compact. Compact design & low installation weight. Because of the wafer design, the valve is a low weight solution with easy installation and limited stress on the piping.

Cost efficient. Exclude your automated ON/OFF valve. With KSC you only need one valve. Other than that you will avoid any process loss and increase the efficiency of the process.

COMMON APPLICATIONS

Water & wastewater / pH Control / Toxic Fluid / Steam /
Lubricating systems / Burners & furnaces / Anti-Surge control /
Vacuum systems / Low pressure steam

BENEFITS OF THE KSC CONSTRUCTION

Its Bi-directional design. Ramén KS is normally installed with the throttling ball sector edge on the inlet side of the valve. Thanks to its bi-directional design, it is more appropriate to mount the valve body in the opposite direction when controlling abrasive media. With the throttling orifice placed on the outlet side of the valve, velocity and thereby abrasion in the valve body is reduced to a minimum or more often to zero.

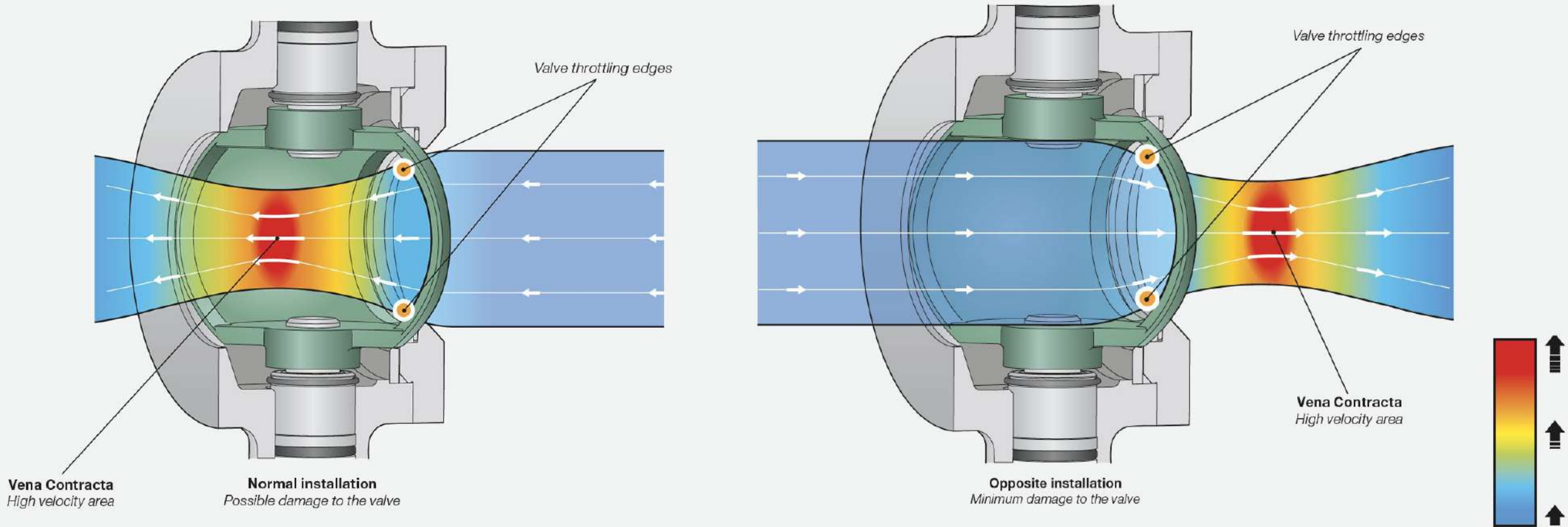

BENEFITS OF THE KSC CONSTRUCTION

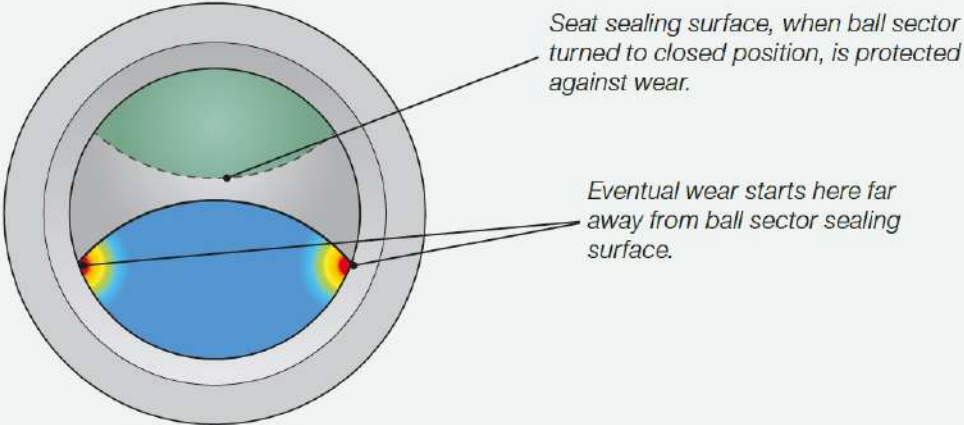

Ramén KS

Wear starts here in this narrow area where shut-off sealing surfaces are located.

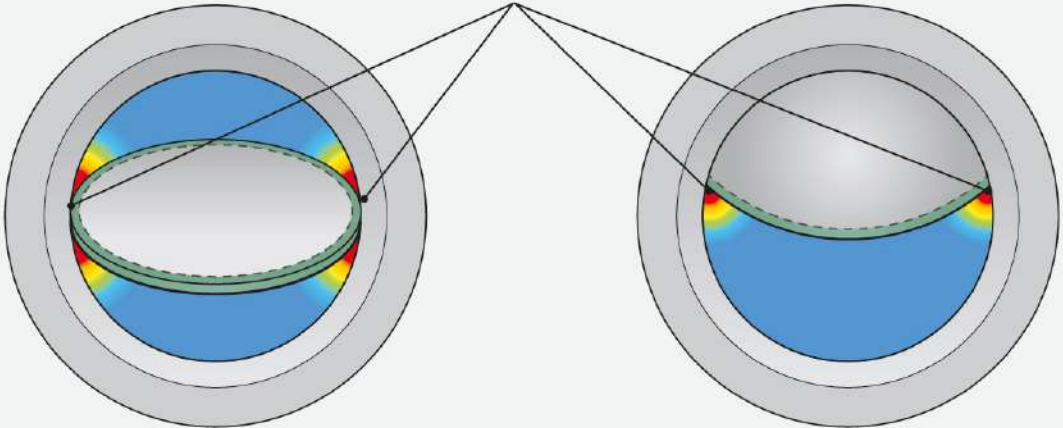

Butterfly valve

Ball segment valve



Increased wear and tear resistance compared to other valves. The Ramén KS valve seat is fully protected by the ball sector in the open position and fully supported from 0° to 90°, whereas in other valve types such as segmented ball valves the seat is fully exposed to media and there is no segment support in the open position. The ball sector design in a Ramén KS offers increased wear-and-tear resistance for abrasive media and a secured tight shut-off with any media.

THE SUSTAINABLE VALVE SOLUTION IN 4 STEPS

1.

Engineering & valve sizing

Our engineers put effort into precise valve sizing, resulting in increased production levels and reduced fugitive emissions. Correct valve sizing also pro-long the product life cycle of the valve package

2.

Manufacturing & purchasing

Our valves are Made in Sweden with locally sourced components. We use renewable energy and continuously review the sustainability of our production methods. We encourage our subcontractors to be environmentally conscious. Ramén Valves are certified acc. to ISO 9001:2015, 14001:2015 and 45001:2018.

3.

In operation

The inherent characteristics of this valve solution results in a productive and sustainable process. The minimum need for maintenance combined with easy access to the spare parts reduce expensive downtime. Energy efficient control components, for example its low power consumption actuators, save cost and spare the environment.

4.

Reconditioning & valve service

The KSC valve solution is designed for easy service and spare part replacements. You can easily recondition the valve package back to factory specifications, using a qualified valve repair company such as Ramén Valves. Valve service maximizes the product life cycle while it minimizes the environmental impact.

TECHNICAL SPECIFICATIONS

Design	Electrical or pneumatic
End connection	Wafer
Nominal sizes	DN 25 - DN 100, ½"-4"
Pressure class	PN 40/25
Operating temperature	-40° C - 170° C
Certificates & approvals	<ul style="list-style-type: none">• CE marked acc. to PED 2014/68/EU, Category II, Module D1• ATEX acc. to directive 2014/34/EU• Fugitive emission standards acc. to ISO 15848-1 and VDI 2440 (TA Luft).

Do you want more technical data? See *Data sheet Ramen Ball Sector valve type KSC*

Thanks for your attention!

Want to know more?



Contact

Stéphane Blanchet

Sales Manager, Ramén Valves

Email: stephane.blanchet@ramenvalves.com

Phone: +46 8 598 931 18

[LinkedIn profile](#)

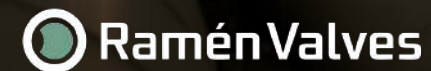

Email: info@ramenvalves.com

Phone: +46 8 598 931 00

Website: www.ramenvalves.com